

General Description

Series D1FP direct operated control NG6 (CETOP 3) valve features extremely high dynamics combined with maximum flow. It is used for high accuracy in positioning of a hydraulic axis, and for controlling force and velocity.

Driven by the new patented VCD® actuator, the D1FP reaches the frequency response of servovalves. Compared with solenoid driven valves, the D1FP can also be used in applications with pressure drops up to 350 Bar (5075 PSI) across the valve. Because of the high flow capability the D1FP can be a substitute for NG10 valves in some cases.

At power-down the spool moves in a defined position. All common input signals are available.

Features

- Servovalve dynamics: -3dB/350Hz at ±5% input signal
- Full flow capacity up to 350 Bar (5075 PSI) pressure drop through the valve
- Maximum tank pressure 350 Bar (5075 PSI) with external drain Y-port
- High flow
- Defined spool positioning in case of loss of electric power supply
- Onboard electronics

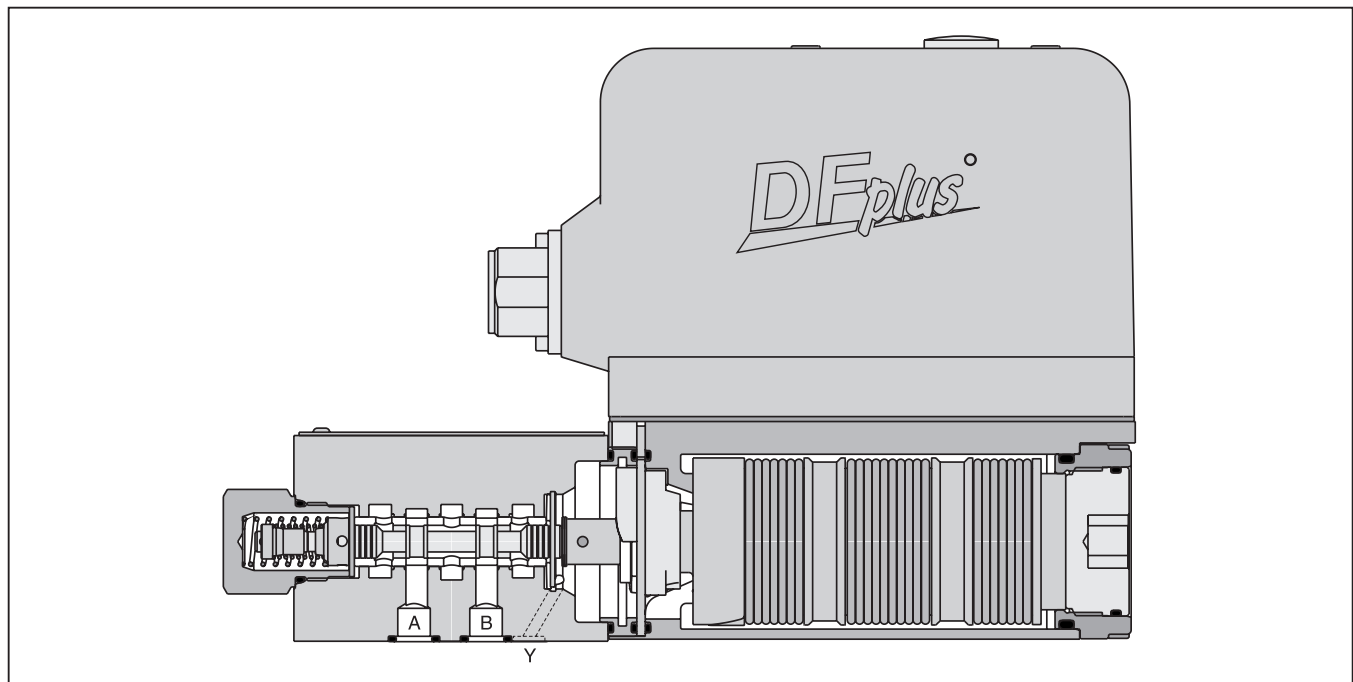
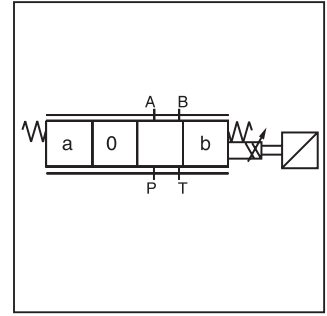
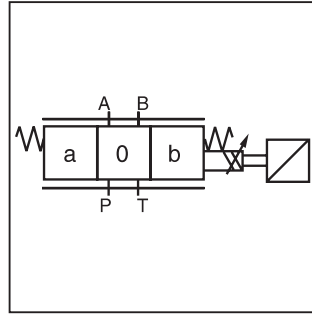
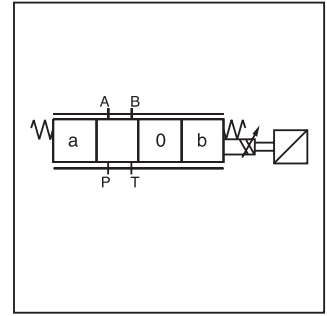
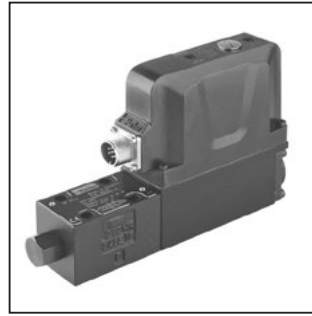

WARNING: This product can expose you to chemicals including Lead, Nickel (Metallic), or 1,3-Butadiene which are known to the State of California to cause cancer, and Lead or 1,3-Butadiene which is known to the State of California to cause birth defects and other reproductive harm. For more information go to www.P65Warnings.ca.gov.

A01_Cat2500.indd, ddp, 04/19



A

D

Directional Control Valve

1

Size
 DIN NG6
 CETOP 3
 NFPA D03

F

Proportional Control

P

VCD

Spool Type

Spool Position on Power Down ¹⁾

9

Y-Port Plugged ⁴⁾

Seal

Input Signal

Options

0

Spool/Sleeve Design

Design Series

NOTE:
 Not required when ordering.

Code	Spool	Flow LPM (GPM) at Δp 35 Bar (508 PSI) per metering edge
Zerolap		
E50M*		40 (10.6)
E50H		25 (6.6)
E50G		16 (4.2)
E50F		12 (3.2)
E50C		6 (1.6)
E50B		3 (0.8)
B60M*	$Q_b = Q_a/2$ 	40 (10.6) / 20 (5.3)
B60H		25 (6.6) / 12.5 (3.3)
B60G		16 (4.2) / 8 (2.1)
B60F		12 (3.2) / 6 (1.6)
B60C		6 (1.6) / 3 (0.8)
B60B		3 (0.8)
Underlap approximately -0.5%		
E55M*		40 (10.6)
E55H		25 (6.6)
E55G		16 (4.2)
E55F		12 (3.2)
E55C		6 (1.6)
E55B		3 (0.8)
Overlap 25%		
E01M*		40 (10.6)
E01H		25 (6.6)
E01G		16 (4.2)
E01F		12 (3.2)
E01C		6 (1.6)
E01B		3 (0.8)
B31M*	$Q_b = Q_a/2$ 	40 (10.6) / 20 (5.3)
B31H		25 (6.6) / 12.5 (3.3)
B31G		16 (4.2) / 8 (2.1)
B31F		12 (3.2) / 6 (1.6)
B31C		6 (1.6) / 3 (0.8)
B31B		3 (0.8)
E02M*		40 (10.6)
E02H		25 (6.6)
E02G		16 (4.2)
E02F		12 (3.2)
E02C		6 (1.6)
E02B		3 (0.8)
B32M*	$Q_b = Q_a/2$ 	40 (10.6) / 20 (5.3)
B32H		25 (6.6) / 12.5 (3.3)
B32G		16 (4.2) / 8 (2.1)
B32F		12 (3.2) / 6 (1.6)
B32C		6 (1.6) / 3 (0.8)
B32B		3 (0.8)

Code	Description
N	Nitrile
V	Fluorocarbon
H	For HFC Fluid

Code	Description
0	6 + PE acc. EN175201-804
5	11 + PE acc. EN175201-804
7	6 + PE + Enable

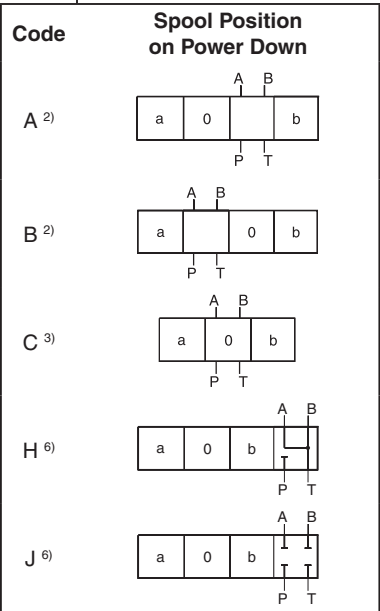

Code	Signal	Flow Direction ⁵⁾
B	+/- 10V	0...+10V -> P-A
E	+/- 20mA	0...+20mA -> P-A
S	4...20mA	12...20mA -> P-A

- 1) On power down the spool moves in a defined position. This cannot be guaranteed in case of single flow path on the control edge A→T resp. B→T with pressure drops above 120 Bar (1740 PSI) or contamination in the hydraulic fluid.
- 2) Approximately 10% opening, only available with zerolap spools and underlap spools.
- 3) Only available with overlap spools.
- 4) Needs to be removed at tank pressure >35 Bar (507.5 PSI).
- 5) Flow direction P→A with Pin D > Pin E.
- 6) Not for flow code M.

* Flow is 32 (8.5) when spool power down options H or J are used.
 Please order plugs separately. See Accessories.

Bolt Kit:
 BK209 (4) 10-24x1.25
 BK375 (4) M5x30
Weight: 5.0 kg (11.0 lbs.)



General		
Design	Direct operated proportional DC valve	
Actuation	VCD® actuator	
Size	NG6 / CETOP 3 / NFPA D03	
Mounting Interface	DIN 24340 / ISO 4401 / CETOP RP121 / NFPA	
Mounting Position	Unrestricted	
Ambient Temperature	[°C]	-20...+50; (-4°F...+122°F)
MTTF _n Value	[years]	75
Vibration Resistance	[g]	10 Sinus 5...2000 Hz acc. IEC 68-2-6 30 Random noise 20...2000 Hz acc. IEC 68-2-36 15 Shock acc. IEC 68-2-27
Hydraulic		
Maximum Operating Pressure	Ports P, A, B 350 Bar (5075 PSI) Port T max. 35 Bar (508 PSI), port Y max. 35 Bar (508 PSI) ¹⁾	
Fluid	Hydraulic oil as per DIN 51524...51535, other on request	
Fluid Temperature	[°C]	-20...+60; (-4°F...+140°F)
Viscosity		
Permitted	[cSt] / [mm ² /s]	20...380 (93...1761 SSU)
Recommended	[cSt] / [mm ² /s]	30...80 (139...371 SSU)
Filtration	ISO 4406 (1999) 18/16/13 (acc. NAS 1638: 7)	
Nominal Flow at Δp=35 Bar (508 PSI) per Control Edge ²⁾	[LPM] [LPM]	3 LPM (0.08 GPM) / 6 LPM (1.6 GPM) / 12 LPM (3.2 GPM) / 25 LPM (6.6 GPM) / 40 LPM (10.6 GPM)
Flow Maximum	90 LPM (23.8 GPM) at Δp=350 Bar (5075 PSI) over two control edges	
Leakage at 100 Bar (1450 PSI)	[ml/ min]	<400 (zerolapped spool); <50 (overlapped spool)
Static / Dynamic		
Step Response at 100% Step ³⁾	[ms]	<3.5
Frequency Response (±5% signal) ³⁾	[Hz]	350 (amplitude ratio -3dB), 350 (phase lag -90°)
Hysteresis	[%]	<0.05
Sensitivity	[%]	<0.03
Temperature Drift	[%/K]	<0.025
Electrical		
Duty Ratio	[%]	100 ED; CAUTION: Coil temperature up to 150°C (302°F) possible
Protection Class	IP65 in accordance with EN 60529 (plugged and mounted)	
Supply Voltage/Ripple	[V]	DC 22 ... 30, ripple <5% eff., surge free
Current Consumption Maximum	[A]	3.5
Pre-Fusing	[A]	4.0 medium lag
Input Signal		
Voltage	[V]	10...0...-10, ripple <0.01% eff., surge free, 0...+10V P->A
Impedance	[kOhm]	100
Current	[mA]	20...0...-20, ripple <0.01% eff., surge free, 0...+20mA P->A
Impedance	[Ohm]	250
Current	[mA]	4...12...20, ripple <0.01% eff., surge free, 12...20mA P->A <3.6 mA = disable, >3.8 mA = according to NAMUR NE43
Impedance	[Ohm]	250
Differential Input Maximum		
Code 0	[V]	30 for terminal D and E against PE (terminal G)
Code 5 / 7	[V]	30 for terminal 4 and 5 against PE (terminal ⊥)
Enable Signal (Only Code 5 / 7)	[V]	5...30, Ri = 9 kOhm
Diagnostic Signal	[V]	+10...0...-10 / +Ub, rated max. 5mA
EMC	EN61000-6-2 / EN61000-6-4	
Electrical Connection	Code 0 Code 5 Code 7	6 + PE acc. EN 175201-804 11 + PE acc. EN 175201-804 6 + PE + Enable
Wiring Miniimum		
Code 0	[mm ²]	7x1.0 (AWG 18) overall braid shield
Code 5	[mm ²]	12x1.0 (AWG 20) overall braid shield
Code 7	[mm ²]	12x1.0 (AWG 18) overall braid shield
Wiring Length Maximum	[m]	50 (164 ft.)

¹⁾ For applications with pT>35 Bar (508 PSI) the Y-port has to be connected and the plug in the Y-port has to be removed.

²⁾ Flow rate for different Δp per control edge: $Q_x = Q_{Nom.} \cdot \sqrt{\frac{\Delta p_x}{\Delta p_{Nom.}}}$

³⁾ Measured with load 100 Bar (1450 PSI) pressure drop/two control edges.

A

Functional Limit

at 25%, 50%, 75% and 100%
 Command Signal

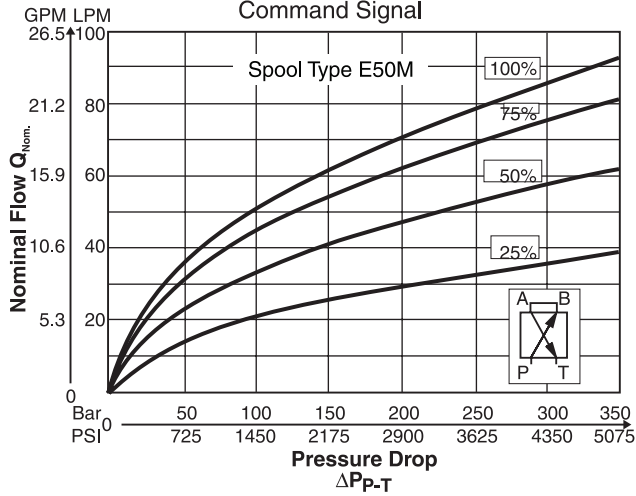

Spool Type E01/E50

Flow Curves

at $\Delta p = 35$ Bar (508 PSI) per metering edge

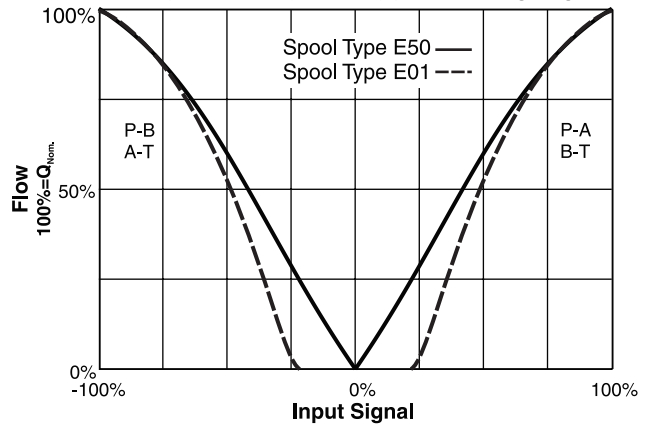

Pressure Gain

100% ΔP_{A-B}

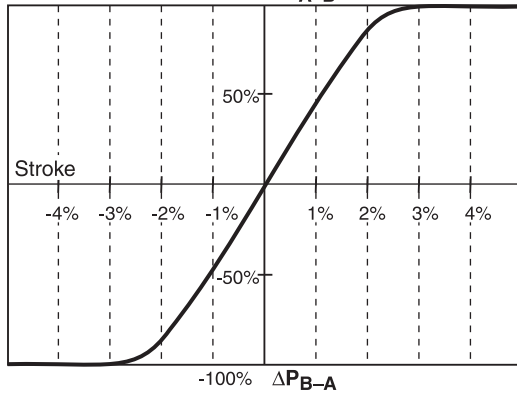

Spool Type B60

Flow Curves

at $\Delta p = 35$ Bar (508 PSI) per metering edge

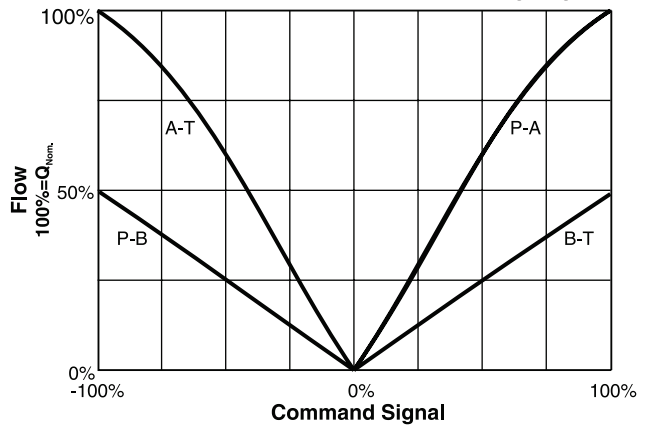

Frequency Response

$\pm 5\%$ Command Signal
 $\pm 90\%$ Command Signal

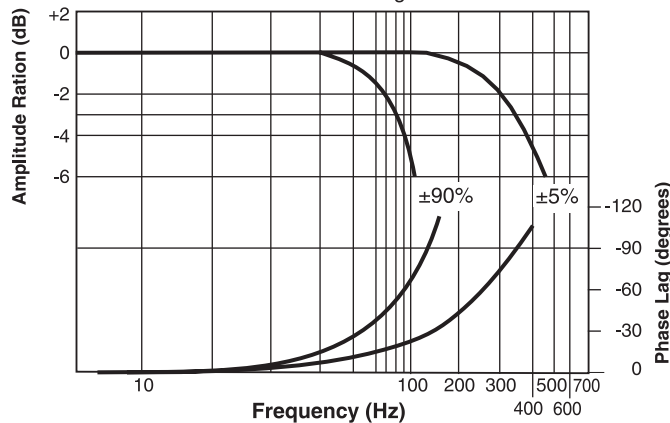

Code 0

6 + PE acc. to EN 175201-804

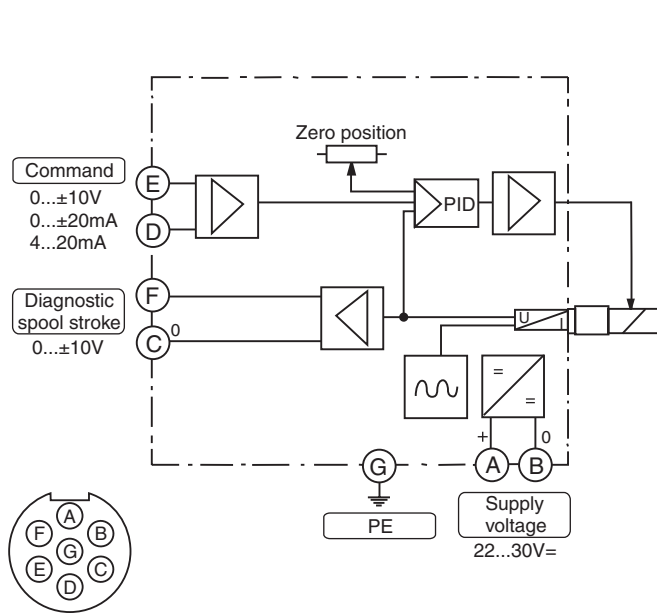

Code 5

11 + PE acc. to EN 175201-804

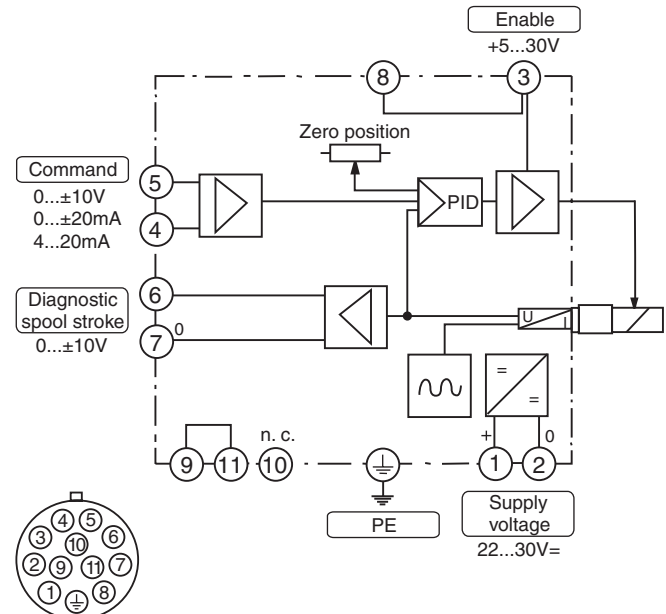

Note: When replacing another valve, verify Pin C is 0 V and not wired as an enable.

Code 7

6 + PE + Enable acc. to EN 175201-804

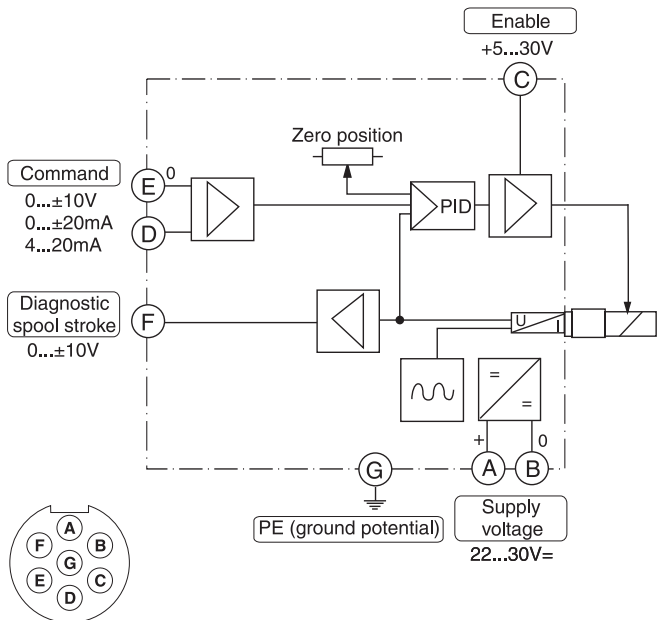

Inch equivalents for millimeter dimensions are shown in (**)

A

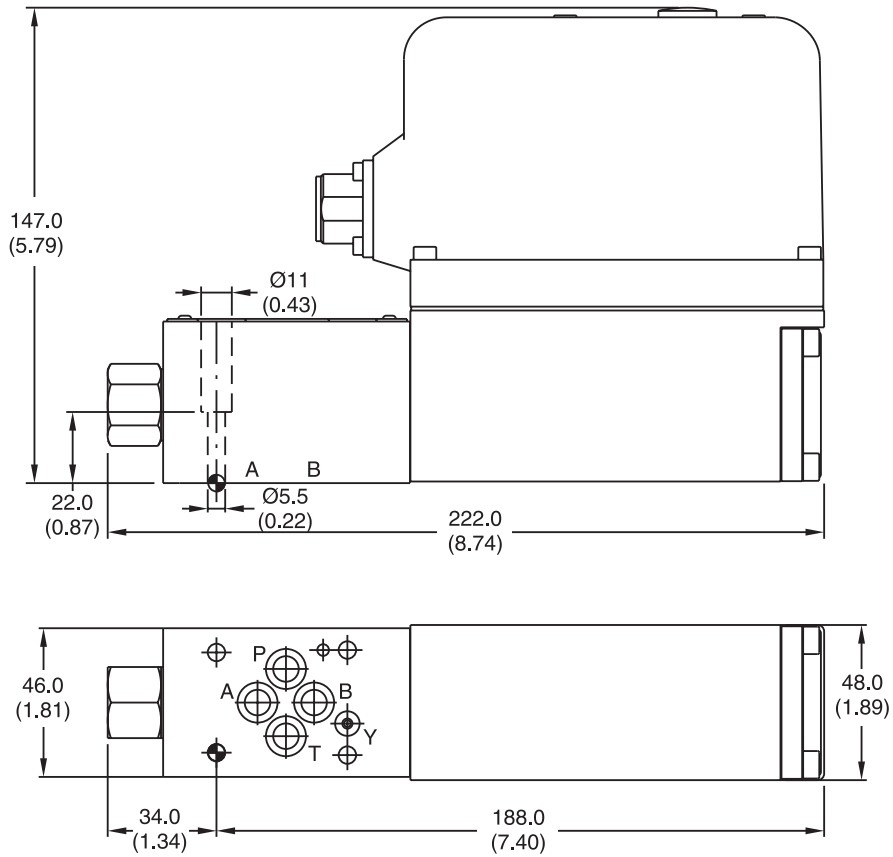

Surface Finish	Kit			Seal Kit
	BK375 BK209	4x M5x30 DIN 912 12.9 4x 10-24x1.25	7.6 Nm (5.6 lb.-ft.) ±15 %	Nitrile: SK-D1FP Fluorocarbon: SK-D1FP-V for HFC Fluid: SK-D1FP-H